

Mini turbine 800/900/1000 series



- 800 Series
- 900 Series
- 1000 Series
- Hall effect detection



OVERVIEW

The principle of operation is very simple. A jet of liquid is directed at a free running Pelton wheel turbine in a specially shaped chamber. The rotation of the rotor is detected with a Hall Effect sensor. The output frequency of these pulses is directly proportional to flow rate and the total number of pulses the total volume passed. The standard bearing material is sapphire as this gives a long trouble free life to the meter. Non-metallic options mean that these meters may be used with very aggressive chemicals and ultra-pure water.



INSTALLATION

The pipe work must be designed in such a way to eliminate reverse flow, and the flow passes through the meter in the direction of the arrow. The meter should be installed in a position that prevents it from draining down as on start-up serious damage could result by “impacting” an empty flowmeter with a high velocity fluid stream. The fluid should be clean and homogenous.

In all cases an upstream filter of at least 80 microns must be fitted. It is recommended that before the flowmeter is installed in the line a “dummy” section of pipe is inserted and the system flushed. This is to eliminate any debris in that section of the line. The pipe must not stress the body of the meter and should be fully supported either side with appropriate isolation valves and in some cases a by-pass valve. When screwing fittings into a threaded body always place the second spanner next to the fitting being inserted, never tighten one fitting against the other across the meter body as this will distort the body and damage the sapphire bearings.

On initial start-up increase the flow slowly to ensure no over speeding of the meter occurs as the air is forced from the line. This is best achieved by monitoring the flow rate and ensuring that a 50% over-range is not exceeded. Never blow a flowmeter with an airline. Care should be taken to ensure that no air enters the system (e.g. leaky pump gland) or that no cavitation takes place. With a volatile liquid we recommend at least twice the vapour pressure plus 1 Bar as the operating back pressure. The user must ensure that the materials of construction are compatible with their fluid. We accept no responsibility for material compatibility; it is the users' responsibility.

Mini turbine 800/900/1000 series



Distributor: DDM GmbH & Co. KG

Phone: +49 661 967 962-0 >>> Email: info@ddm-sensors.de >>> Web: www.ddm-sensors.de



ELECTRICAL CHARACTERISTICS

Hall effect sensor

Supply	4.5 – 24Vdc
Temp range	-20 to 125°C
Rise & fall times	1.5uS max
Supply current	7.5mA typ
Switch current	10mA max

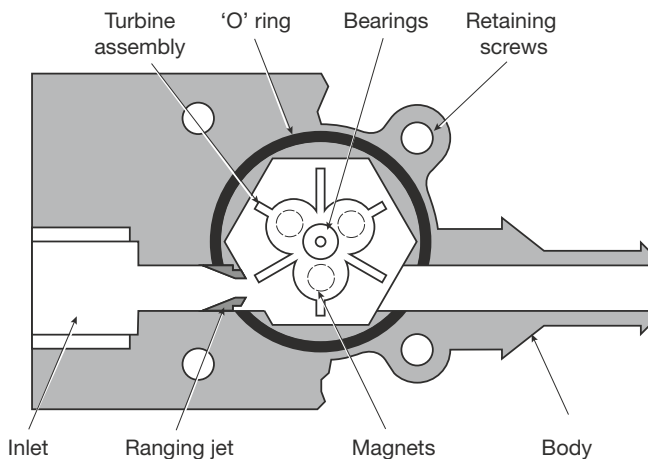

All meters do not look the same, this illustration is an amalgam and is for guidance only.



COMMISSIONING

If problems occur during commissioning always check the fundamentals first.

- Is the flowmeter/instrument the correct one for the installation?
- Is the power connected to the meter and the instrument, and is it turned on?
- Is the instrument set/wired correctly? I/P port, pulse type, frequency span, units etc.
- Where possible check the O/P from the flowmeter with an oscilloscope before proceeding
- Was the line flushed prior to installing the meter?
- Was the flow increased slowly?
- Is the meter blocked?

If you cannot find a solution ask your supplier for technical support

Pressure drop Vs flow rate for model suffix number

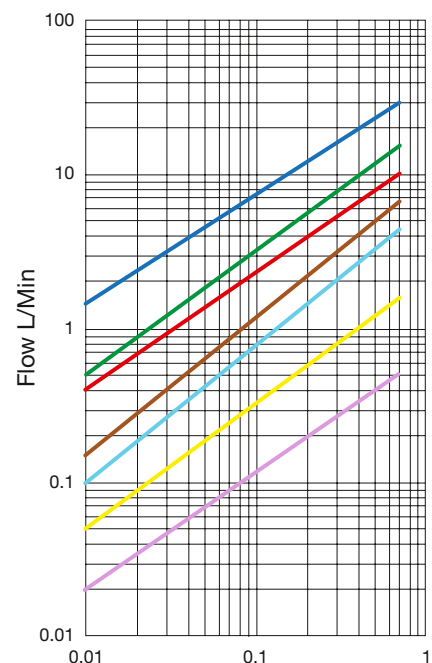

Pressure drop Bar

- 03
- 10
- 15
- 24
- 45
- 65
- 00 (1000 series only)

Mini turbine 800/900/1000 series



Distributor: DDM GmbH & Co. KG

Phone: +49 661 967 962-0 >>> Email: info@ddm-sensors.de >>> Web: www.ddm-sensors.de

It is recommended that all “signal” cables are screened and run separately to power lines and switched inductive loads and are located well away from inverters and other “noisy” apparatus. Always use sound wiring practice. Hall effect sensors (NPN or PNP) require an external pull-up resistor connected between the output and a suitable power supply to attain a pulse. Typically the flowmeter PSU may be used but sometimes a dc pulse, which is of a different voltage, may be required e.g. using a PLC with a 24V PSU and an internal 5V rail for the pull-up resistor/pulse input.

Connection options

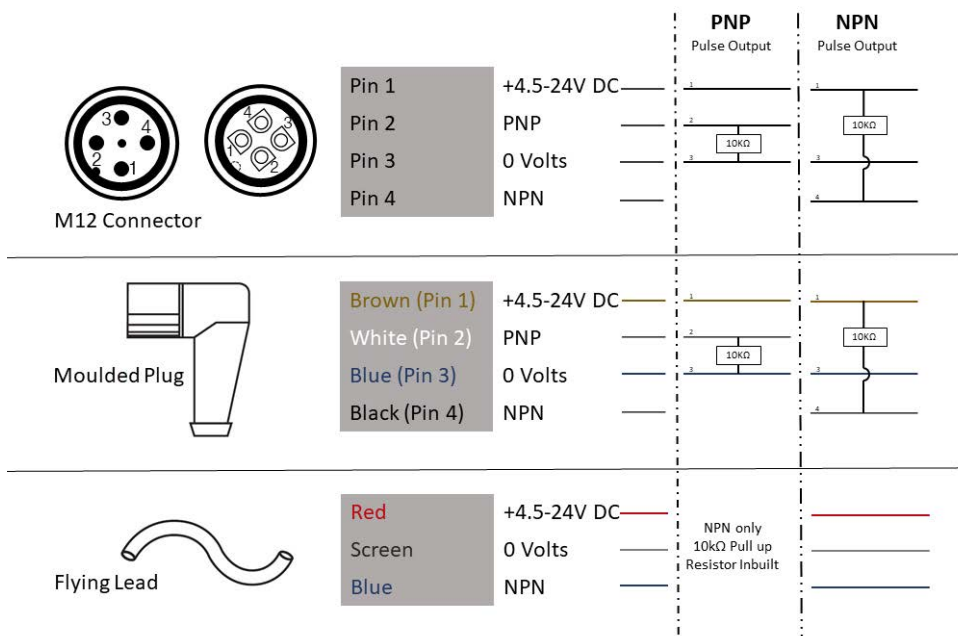

TITAN ENTERPRISES LTD.

Coldharbour Business Park, Sherborne, Dorset DT9 4JW

Tel: **(44) 01935 812790**

Email: sales@flowmeters.co.uk

www.flowmeters.co.uk

For reference only; for latest information contact your local distributor.